

# Model ED 720 | Drying and heating chambers with natural convection

The strengths of a BINDER ED series drying chamber include routine drying and sterilization tasks up to 300 °C. Thanks to the natural convection, all thermal processes which use this drying chamber are highly efficient. The ED series ensures fast, uniform drying.

## BENEFITS

- Best energy efficiency on the market
- Excellent temporal and spatial temperature accuracy
- USB connection for recording data
- Temperature range up to 300 °C

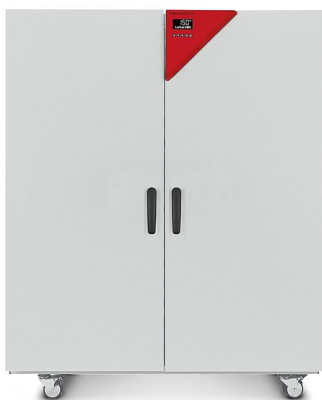

Model 720

## MAIN FEATURES

- Temperature range: ambient temperature plus 5 °C to 300 °C
- Up to 30% lower energy consumption compared to conventional units on the market
- High temperature accuracy thanks to APT.line™ technology
- Natural convection
- Controller with LCD display
- Electromechanical control of the exhaust air flap
- 2 chrome-plated racks
- Class 2 integrated independent adjustable temperature safety device (DIN 12880) with visual alarm
- Ergonomic handle design
- USB port for recording data

## ORDERING INFORMATION

Interior volume [L]	Voltage	Option model	Version	Art.-No.
Model ED 720				
743	400 V 3~ ph 50/60 Hz	Standard	ED720-400V	9010-0341

## TECHNICAL DATA

Description	ED720-400V <sup>1</sup>
Article Number	9010-0341
<b>Performance Data Temperature</b>	
Temperature range 5 °C above ambient temperature to [°C]	300
Temperature variation at 150 °C [± K]	3.2
Temperature fluctuation at 150 °C [± K]	0.8
Heating-up time to 150 °C [min]	85
Recovery time after 30 seconds door open at 150 °C [min]	25
<b>Electrical data</b>	
Rated Voltage [V]	400
Power frequency [Hz]	50/60
Nominal power [kW]	4.1
Unit fuse [A]	16
Phase (Nominal voltage)	3~
<b>Internal Dimensions</b>	
Depth [mm]	605
Height [mm]	1280
Width [mm]	960
<b>Housing dimensions not incl. fittings and connections</b>	
Width net [mm]	1165
Height net [mm]	1590
Depth net [mm]	870
<b>Measures</b>	
Wall clearance back [mm]	160
Wall clearance sidewise [mm]	100
Interior volume [L]	743
Net weight of the unit (empty) [kg]	169
permitted load [kg]	315
Load per rack [kg]	45
<b>Doors</b>	
Inner doors	2
Unit doors	2
<b>Environment-specific data</b>	
Energy consumption at 150 °C [Wh/h]	700
<b>Fixtures</b>	
Number of shelves (std./max.)	2/16

<sup>1</sup> All technical data is specified for unloaded units with standard equipment at an ambient temperature of +22 °C ±3 °C and a power supply voltage fluctuation of ±10%. The temperature data is determined in accordance to BINDER factory standard following DIN 12880, observing the recommended wall clearances of 10 % of the height, width, and depth of the inner chamber. All indications are average values, typical for units produced in series. We reserve the right to change technical specifications at any time.

## DIMENSIONS incl. fittings and connections [mm]

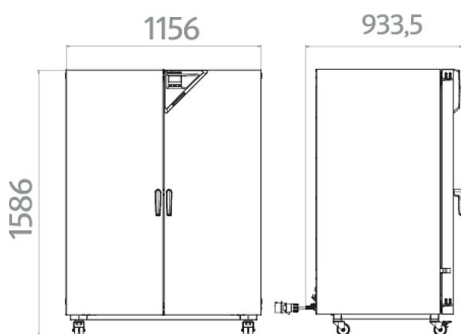

## OPTIONS AND ACCESSORIES

Designation	Description	*	Art.-No.
Access port with silicone plug	back		
	10 mm	01	8012-1282
	30 mm	01	8012-0540
	50 mm	01	8012-0546
	left		
	10 mm	01	8012-1275
	30 mm	01	8012-1018
	50 mm	01	8012-1022
	100 mm	01	8012-1030
	right		
	10 mm	01	8012-1268
	30 mm	01	8012-1017
	50 mm	01	8012-1021
	100 mm	01	8012-1031
	top		
	10 mm	01	8012-1262
	30 mm	01	8012-0539
	50 mm	01	8012-0545
	100 mm	01, 10	8012-1029
	Analog output 4-20 mA	for temperature values (output not adjustable)	02
APT-COM™ 4 BASIC-Edition	for simple logging and documentation requirements with up to 5 networked units. version 4, BASIC edition	19	9053-0039
APT-COM™ 4 GLP-Edition	for working under GLP-compliant conditions. Measured values are documented in a tamper-proof way in line with the requirements of FDA Regulation 21 CFR 11. version 4, GLP edition	19	9053-0042
APT-COM™ 4 PROFESSIONAL-Edition	convenient unit and user management built on the BASIC edition. Suitable for networking up to 100 units. version 4, PROFESSIONAL edition	19	9053-0040
Calibration certificate, expanded	for temperature; for extending the measurement in center of chamber to include another test temperature	-	8012-1115
Calibration certificate, temperature	for temperature, measurement in center of chamber at specified temperature	-	8012-1134
	temperature measurement incl. certificate and 27 measuring points at specified temperature	-	8012-1593
	temperature measurement incl. certificate, 15- 18 measuring points at specified temperature	-	8012-1572
	temperature measurement incl. certificate, 9 measuring points at specified temperature	-	8012-1551
Class 3.1 independent temperature safety device	with visual alarm (DIN 12880)	04, 12	8012-0985
Clock	battery-backed	-	8012-1640
Data Logger Kit	T 350: For continuous temperature logging from 0 °C to 350 °C; kit includes 1 data logger, Pt 100 sensor with 2 m extension cable and 1 magnetic fixture for mounting to the BINDER unit	19	8012-0714

\* Notes › See last page

Designation	Description	*	Art.-No.
Data Logger Software	LOG ANALYZE software kit, configuration and evaluation software for all BINDER Data Logger Kits (incl. USB data cable)	19	8012-0821
Door gasket	made of FKM, silicone-free	03	8012-1013
Door lock	lockable door handle	-	8012-1817
Ethernet interface	for Multi Management Software APT-COM™	-	8012-1836
Inner chamber, reinforced	max. total load 350 kg	-	8012-1827
Instrument tray	with lid made from 18/8 stainless steel, stackable, dimensions: 230 x 133 x 45 mm	-	4022-0123
	with lid made from 18/8 stainless steel, stackable, dimensions: 315 x 215 x 60 mm	-	4022-0124
Interior lighting	with two 15 W light bulbs	-	8012-1824
	400 V option model		
Measurement of air exchange rate	in accordance with ASTM D5374, definition and protocol according to ambient temperature	-	8012-0195
Overheating alarm	audible, can be switched off, adjustable limit on the independent temperature safety device	-	8012-1635
pH-neutral detergent	concentrated, for gentle remove of residual contaminants; 1 kg	-	1002-0016
Pt 100 temperature sensor	additional flexible Pt 100, interior, for displaying the temperature on the unit display	-	8012-1619
Rack	chrome plated	-	6004-0179
	stainless steel	-	6004-0163
Rack, heavy load	Stainless steel, max. load per rack 70 kg	-	6004-0205
Shelf, perforated	Stainless steel	-	6004-0195
Viewing window and interior lighting	viewing window (triple insulating glass) in door, 300 x 480 mm, and 30 W interior	-	8012-1830
	400 V option model		

\* Notes › See last page

## SERVICES

Designation	Description	*	Art.-No.
<b>Installation services</b>			
Installation	and set up of unit at operating location, connect to existing connections	13, 18	DL10-0100
Instruction	unit function instructions for operation and programming of the controller	18	DL10-0500
<b>Preventive maintenance</b>			
Preventive maintenance	Executive of equipment inspection according to maintenance plan	14, 18	DL20-0200
<b>Calibration services</b>			
Calibration temperature incl. certificate	including certificate, one measuring point in center of chamber at specified temperature	14, 16, 17, 18	DL30-0101
Measurement of air exchange rate	including certificate (in accordance with ASTM D5374)	14, 16, 17, 18	DL33-0000
Temperature measurement 18 measuring points	including certificate, 18 measuring points at specified temperature	14, 16, 17, 18	DL30-0118
Temperature measurement 27 measuring points	including certificate, 27 measuring points at specified temperature	14, 16, 17, 18	DL30-0127
Temperature measurement 9 measuring points	including certificate, 9 measuring points at specified temperature	14, 16, 17, 18	DL30-0109
<b>Validation services</b>			
Execution of IQ/OQ	in accordance with qualification folder	15, 18, 20	DL40-0100
Execution of IQ/OQ/PQ	in accordance with customer's requirement, price: on request	15, 18	DL44-0500
Qualification folder IQ/OQ	supporting documents for validation performed by customer, consisting of: IQ/OQ checklists, unit schematics, QM certificate in accordance with ISO 9001	15, 18, 20	8012-0761

\* Notes › See last page

Designation	Description	*	Art.-No.
Qualification folder IQ/OQ/PQ	supporting documents for validation performed by customer, in accordance with customer's requirement, extension of Qualification folder IQ/OQ by chapter PQ	15, 18	8012-0942
<b>Warranty service</b>			
Extension of the warranty from 2 to 3 years	beginning with the date of delivery, wearing parts are not included	-	DL00-2041
Extension of the warranty from 2 to 5 years	beginning with the date of delivery, wearing parts are not included	-	DL00-2042

\* Notes › See last page



**Wolflabs**

# Wolf Laboratories Limited

[www.wolflabs.co.uk](http://www.wolflabs.co.uk)

Tel: 01759 301142

Fax: 01759 301143

[sales@wolflabs.co.uk](mailto:sales@wolflabs.co.uk)



**Use the above details to contact us if this literature doesn't answer all your questions.**

**Pricing on any accessories shown can be found by keying the part number into the search box on our website.**

The specifications listed in this brochure are subject to change by the manufacturer and therefore cannot be guaranteed to be correct. If there are aspects of the specification that must be guaranteed, please provide these to our sales team so that details can be confirmed.

